

THERE ARE MORE CESSNAS FLYING THAN ANY OTHER MAKE



1965

CESSNA

MODEL 172 AND SKYHAWK

OWNER'S
MANUAL

WORLD'S LARGEST PRODUCER OF GENERAL AVIATION AIRCRAFT SINCE 1956



TAKE YOUR CESSNA HOME
FOR SERVICE AT THE SHIELD
OF THE CESSNA SHIELD

CESSNA AIRCRAFT COMPANY

WICHITA, KANSAS

PERFORMANCE - SPECIFICATIONS

	MODEL 172	SKYHAWK
GROSS WEIGHT	2300 lbs	2300 lbs
SPEED:		
Top Speed at Sea Level	138 mph	139 mph
Cruise, 75% Power at 7000 ft	130 mph	131 mph
RANGE:		
Cruise, 75% Power at 7000 ft	550 miles	555 miles
36 Gal. No Reserve	4.2 hours	4.2 hours
Optimum Range at 10,000 ft	130 mph	131 mph
36 Gal. No Reserve	670 miles	670 miles
RATE OF CLIMB AT SEA LEVEL	102 mph	102 mph
SERVICE CEILING	645 fpm	645 fpm
TAKE-OFF:		
Ground Run	865 ft	865 ft
Total Distance Over 50-Foot Obstacle	1525 ft	1525 ft
LANDING:		
Landing Roll	520 ft	520 ft
Total Distance Over 50-Foot Obstacle	1250 ft	1250 ft
EMPTY WEIGHT (Approximate)	1260 lbs	1330 lbs
BAGGAGE	120 lbs	120 lbs
WING LOADING: Pounds/Sq Foot	13.2	13.2
POWER LOADING: Pounds/HP	15.9	15.9
FUEL CAPACITY: Total	39 gal.	39 gal.
OIL CAPACITY: Total	8 qts	8 qts
PROPELLER: Fixed Pitch (Diameter)	76 inches	76 inches
ENGINE:		
Continental Engine No.	O-300-C*	O-300-D
Horse Power	145	145

*The Model F172, which is manufactured by Reims Aviation S.A., Reims (Marne) France, is identical to the 172 except that it is powered by an O-300-D engine, manufactured under license by Rolls Royce, Crewe, England. All 172 information in this manual pertains to the F172 as well.

FIG. 1-13
(REV. 1-6-9-01)

COPYRIGHT © 1984
Cessna Aircraft Company
Wichita, Kansas USA

CONGRATULATIONS

Welcome to the ranks of Cessna owners! Your Cessna has been designed and constructed to give you the most in performance, economy, and comfort. It is our desire that you will find flying it, either for business or pleasure, a pleasant and profitable experience.

This Owner's Manual has been prepared as a guide to help you get the most pleasure and utility from your Model 172/Skyhawk. It contains information about your Cessna's equipment, operating procedures, and performance; and suggestions for its servicing and care. We urge you to read it from cover to cover, and to refer to it frequently.

Our interest in your flying pleasure has not ceased with your purchase of a Cessna. World-wide, the Cessna Dealer Organization backed by the Cessna Service Department stands ready to serve you. The following services are offered by most Cessna Dealers:

FACTORY TRAINED MECHANICS to provide you with courteous expert service.

FACTORY APPROVED SERVICE EQUIPMENT to provide you with the most efficient and accurate workmanship possible.

A STOCK OF GENUINE CESSNA SERVICE PARTS on hand when you need them.

THE LATEST AUTHORITY INFORMATION FOR SERVICING CESSNA AIRPLANES, since Cessna Dealers have all of the Service Manuals and Parts Catalogs, kept current by Service Letters and Service News Letters, published by Cessna Aircraft Company.

We urge all Cessna owners to use the Cessna Dealer Organization to the fullest.

A current Cessna Dealer Directory accompanies your new airplane. The Directory is revised frequently, and a current copy can be obtained from your Cessna Dealer. Make your Directory one of your cross-country flight planning aids; a warm welcome awaits you at every Cessna Dealer.

TABLE OF CONTENTS

Page =

SECTION I - OPERATING CHECK LIST	1-1
SECTION II - DESCRIPTION AND OPERATING DETAILS	2-1
SECTION III - OPERATING LIMITATIONS	3-1
SECTION IV - CARE OF THE AIRPLANE	4-1
OWNER FOLLOW-UP SYSTEM	4-8
SECTION V - OPERATIONAL DATA	5-1
SECTION VI- OPTIONAL SYSTEMS	6-1
ALPHABETICAL INDEX	Index-1

This manual describes the operation and performance of both the Cessna Model 172 and the Cessna Skyhawk. Equipment described as "Optional" denotes that the subject equipment is optional on the Model 172. Much of this equipment is standard on the Skyhawk model.

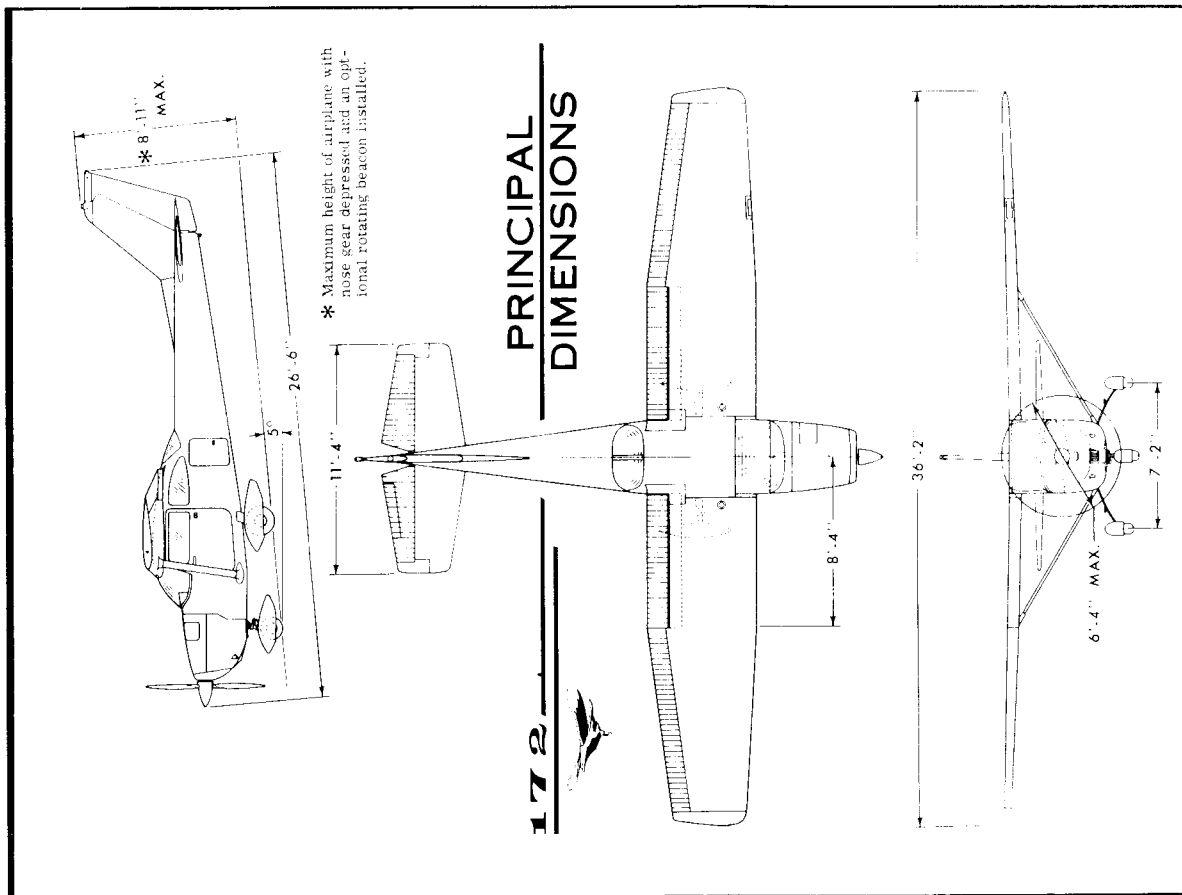

Section I

OPERATING CHECK LIST

One of the first steps in obtaining the utmost performance, service, and flying enjoyment from your Cessna is to familiarize yourself with your airplane's equipment, systems, and controls. This can best be done by reviewing this equipment while sitting in the airplane. Those items whose function and operation are not obvious are covered in Section II.

Section I lists, in Pilot's Check List form, the steps necessary to operate your airplane efficiently and safely. It is not a check list in its true form as it is considerably longer, but it does cover briefly all of the points that you should know for a typical flight.

The flight and operational characteristics of your airplane are normal in all respects. There are no "unconventional" characteristics or operations that need to be mastered. All controls respond in the normal way within the entire range of operation. All airspeeds mentioned in Sections I and II are indicated airspeeds. Corresponding calibrated airspeed may be obtained from the Airspeed Correction Table in Section V.

BEFORE ENTERING THE AIRPLANE.

- (1) Make an exterior inspection in accordance with figure 1-1.

BEFORE STARTING THE ENGINE.

- (1) Seats and Seat Belts -- Adjust and lock.
- (2) Brakes -- Test and set.
- (3) Master Switch -- "ON."
- (4) Fuel Selector -- "BOTH ON."

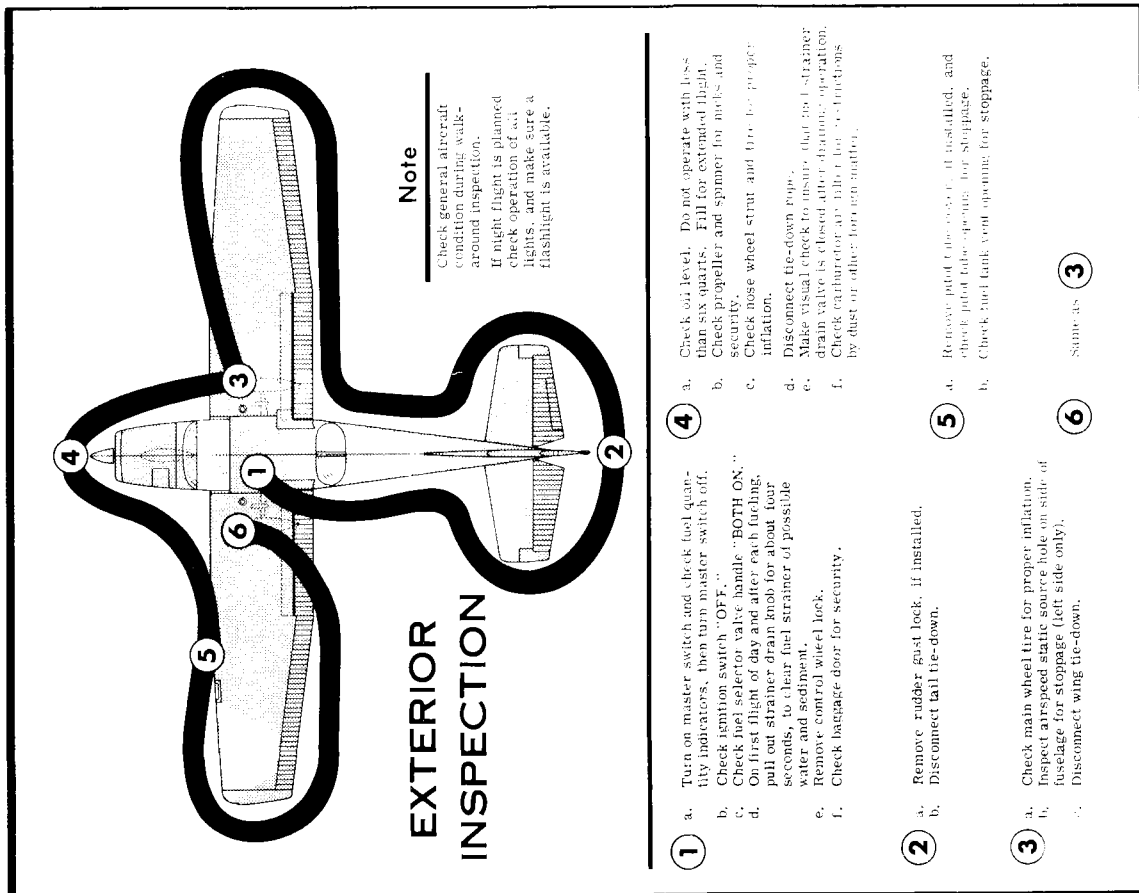

Figure 1-1.

STARTING THE ENGINE.

- (1) Carburetor Heat -- Cold.
 - (2) Mixture -- Rich.
 - (3) Primer -- As required.
 - (4) Ignition Switch -- "BOTH."
 - (5) Throttle -- Open 1/8".
 - (6) Propeller Area -- Clear.
 - (7) Starter -- Engage.
- (3) Brakes -- Apply.
 - (4) Power -- Full throttle.
 - (5) Brakes -- Release.
 - (6) Elevator Control -- Slightly tail low.
 - (7) Climb Speed -- 65 MPH (with obstacles ahead).

CLIMB.

NORMAL CLIMB.

- (1) Airspeed -- 80 to 90 MPH.
- (2) Power -- Full throttle.
- (3) Mixture -- Full rich (unless engine is rough).

MAXIMUM PERFORMANCE CLIMB.

- (1) Airspeed -- 80 MPH at sea level to 77 MPH at 10,000 feet.
- (2) Power -- Full throttle.
- (3) Mixture -- Full rich (unless engine is rough).

TAKE-OFF.

NORMAL TAKE-OFF.

- (1) Wing Flaps -- 0°
- (2) Carburetor Heat -- Cold.
- (3) Power -- Full throttle (applied smoothly).
- (4) Elevator Control -- Lift nosewheel at 60 MPH.
- (5) Climb Speed -- 85 MPH.

MAXIMUM PERFORMANCE TAKE-OFF.

- (1) Wing Flaps -- 0°
- (2) Carburetor Heat -- Cold.

CRUISING.

- (1) Power -- 2200 to 2700 RPM.
- (2) Trim Tab -- Adjust.
- (3) Mixture -- Lean.

LET-DOWN.

- (1) Mixture -- Rich.
- (2) Power -- As desired.
- (3) Carburetor Heat -- As required to prevent carburetor icing.

BEFORE LANDING.

- (1) Fuel Selector -- "BOTH ON."
- (2) Mixture -- Rich.
- (3) Airspeed -- 70 - 80 MPH (flaps up).
- (4) Carburetor Heat -- Apply before closing throttle.
- (5) Wing Flaps -- As desired (below 100 MPH).
- (6) Airspeed -- 65 to 75 MPH (flaps down).

NORMAL LANDING.

- (1) Touchdown -- Main wheels first.
- (2) Landing Roll -- Lower nosewheel gently.
- (3) Braking -- Minimum required.

AFTER LANDING.

- (1) Wing Flaps -- Up
- (2) Carburetor Heat -- Cold.

SECURE AIRCRAFT.

- (1) Mixture -- Full lean.
- (2) All Switches -- Off.
- (3) Brakes -- Set.
- (4) Control Lock -- Installed.

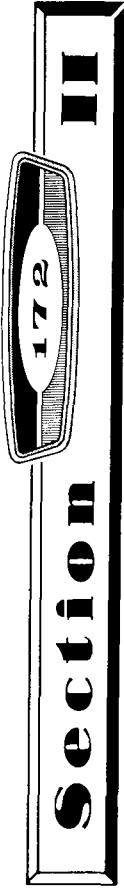

DESCRIPTION AND OPERATING DETAILS

The following paragraphs describe the systems and equipment whose function and operation is not obvious when sitting in the airplane. This section also covers in somewhat greater detail some of the items listed in Check List form in Section I that require further explanation.

FUEL SYSTEM.

Fuel is supplied to the engine from two aluminum tanks, one in each wing. From these tanks, fuel flows by gravity through a selector valve and a strainer to the carburetor.

Refer to figure 2-1 for fuel quantity data. For fuel system servicing information, refer to Lubrication and Servicing Procedures in Section IV.

FUEL QUANTITY DATA (U.S. GALLONS)					
TANKS	NO.	USABLE FUEL ALL FLIGHT CONDITIONS	ADDITIONAL USABLE FUEL (LEVEL FLIGHT)	UNUSABLE FUEL (LEVEL FLIGHT)	TOTAL FUEL VOLUME EACH
LEFT WING	1	18.0 gal.	1.0 gal.	0.5 gal.	19.5 gal.
RIGHT WING	1	18.0 gal.	1.0 gal.	0.5 gal.	19.5 gal.

Figure 2-1

FUEL STRAINER DRAIN KNOB.

Refer to fuel strainer servicing procedures, Section IV.

ELECTRICAL SYSTEM.

Electrical energy is supplied by a 14-volt, direct-current system powered by an engine-driven generator. A 12-volt battery is located on the left-hand forward portion of the firewall.

CIRCUIT BREAKERS.

All electrical circuits in the airplane, except the clock circuit, are protected by circuit breakers. The clock has a separate fuse mounted adjacent to the battery. The stall warning transmitter and horn circuit and turn-and-bank indicator circuit are protected by a single automatically resetting circuit breaker mounted behind the instrument panel. The remaining circuits are protected by "push-to-reset" breakers on the instrument panel.

GENERATOR WARNING LIGHT.

The red generator warning light indicates generator output. The light remains off as long as the generator functions properly. If a malfunction interrupts generator output, the light will illuminate. It also will illuminate when the battery or external power is on, before starting the engine, and whenever engine speed is insufficient to produce generator output. The light does not show battery drain.

LANDING LIGHTS (OPT).

A three-position, push-pull switch controls the optional landing lights. To turn one lamp on for taxiing, pull the switch out to the first stop. To turn both lamps on for landing, pull the switch out to the second stop.

ROTATING BEACON (OPT).

The rotating beacon should not be used when flying through clouds or overcast; the moving beams reflected from water droplets or particles in the atmosphere, particularly at night, can produce vertigo and loss of orientation.

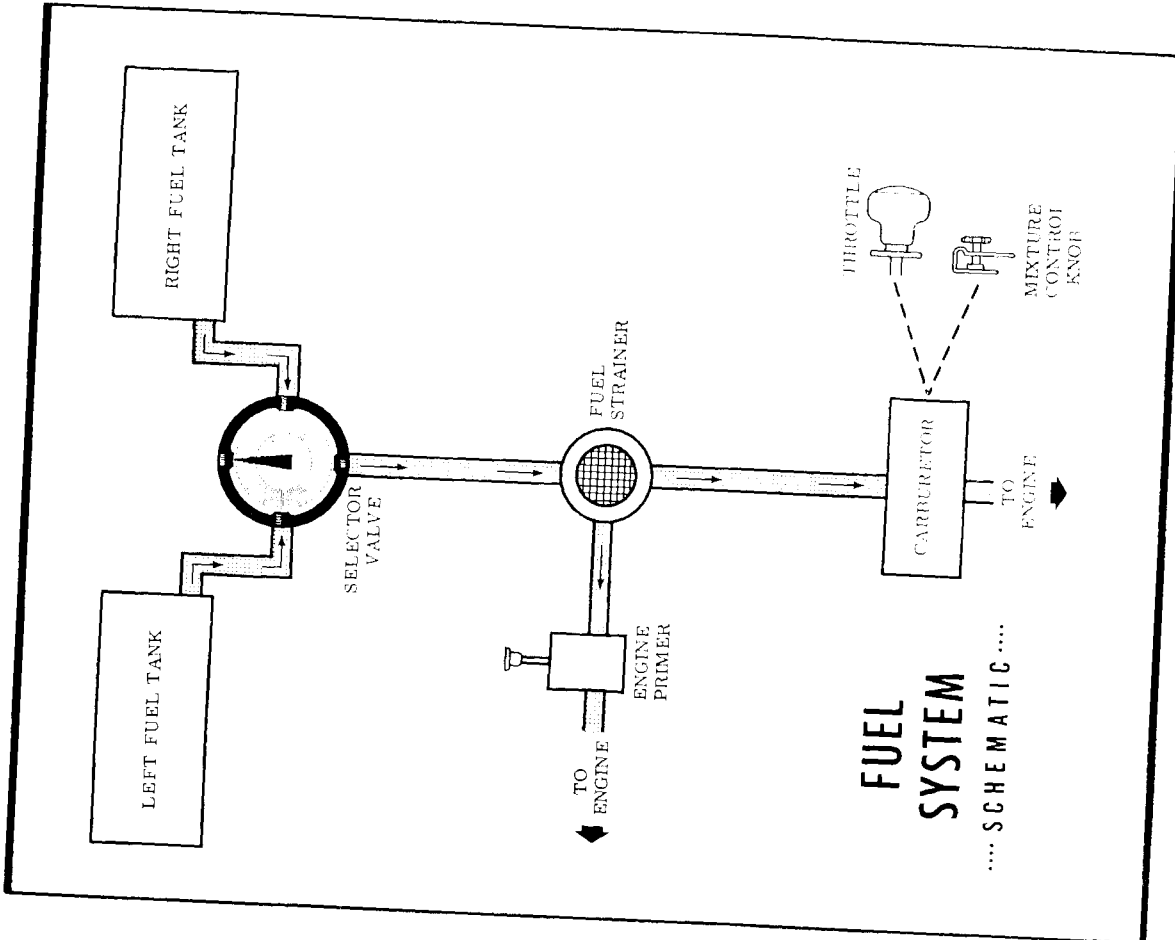

Figure 2-2.

CABIN HEATING AND VENTILATION SYSTEM.

For cabin ventilation, pull the "CABIN AIR" knob out. To raise the air temperature, pull the "CABIN HT" knob out approximately 1/4" to 1/2" for a small amount of cabin heat. Additional heat is available by pulling the knob out farther; maximum heat is available with the "CABIN HT" knob pulled full out and the "CABIN AIR" knob pushed full in. When no heat is desired in the cabin, the "CABIN HT" knob is pushed full in.

Front cabin heat and ventilating air is supplied by outlet holes spaced across a cabin manifold just forward of the pilot's and copilot's feet. Rear cabin heat and air is supplied by two ducts from the manifold, one extending down each side of the cabin. Windshield defrost air is also supplied by a duct leading from the cabin manifold.

Separate adjustable ventilators supply additional air; one near each upper corner of the windshield supplies air for the pilot and copilot, and two optional ventilators in the rear cabin ceiling supply air to the rear seat passengers.

STARTING ENGINE.

Ordinarily the engine starts easily with one or two strokes of the primer in warm temperatures to six strokes in cold weather, with the throttle open approximately 1/8 inch. In extremely cold temperatures, it may be necessary to continue priming while cranking.

Weak intermittent explosions followed by puffs of black smoke from the exhaust stack indicates overpriming or flooding. Excess fuel can be cleared from the combustion chambers by the following procedure: Set the mixture control full lean and the throttle full open; then crank the engine through several revolutions with the starter. Repeat the starting procedure without any additional priming.

If the engine is underprimed (most likely in cold weather with a cold engine) it will not fire at all, and additional priming will be necessary. As soon as the cylinders begin to fire, open the throttle slightly to keep it running.

After starting, if the oil gage does not begin to show pressure within 30 seconds in the summertime and about twice that long in very cold weather, stop engine and investigate. Lack of oil pressure can cause

TAXIING DIAGRAM

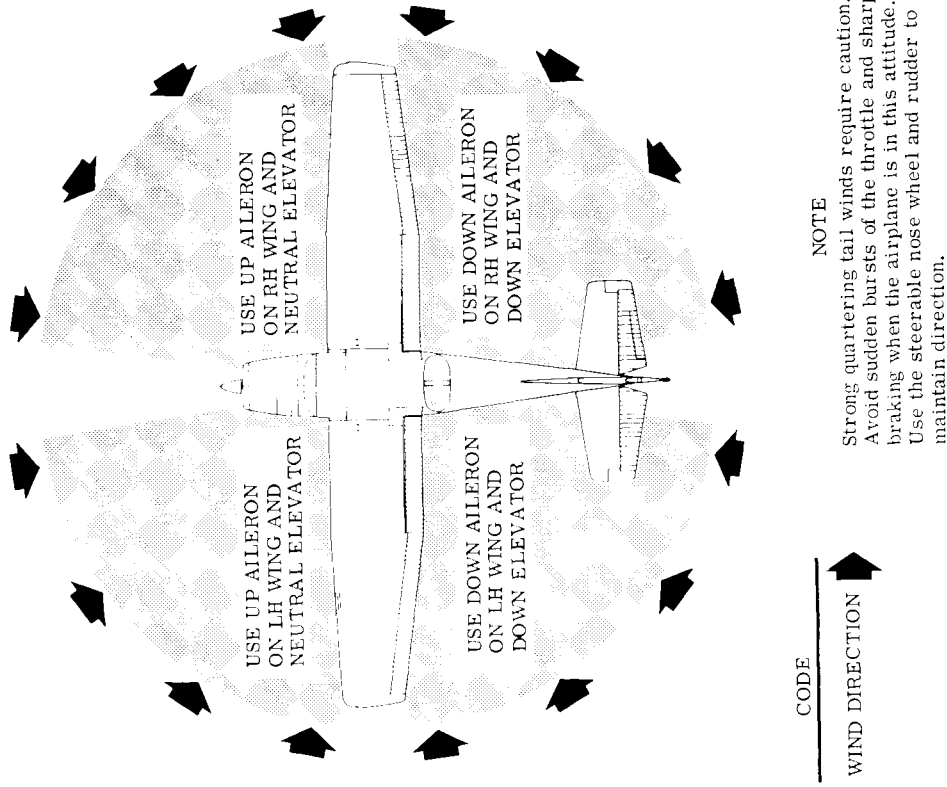

Figure 2-3.

serious engine damage. After starting, avoid the use of carburetor heat unless icing conditions prevail.

TAXIING.

When taxiing, it is important that speed and use of brakes be held to a minimum and that all controls be utilized (see taxiing diagram, figure 2-3) to maintain directional control and balance.

Taxiing over loose gravel or cinders should be done at low engine speed to avoid abrasion and stone damage to the propeller tips.

BEFORE TAKE-OFF.

WARM - UP.

Since the engine is closely cowled for efficient in-flight engine cooling, precautions should be taken to avoid overheating during prolonged engine operation on the ground.

MAGNETO CHECK.

The magneto check should be made at 1600 RPM as follows: Move the ignition switch first to "R" position, and note RPM. Next move the switch back to "BOTH" position to clear the other set of plugs. Then move the switch to the "L" position and note RPM. The difference between the two magnetos operated individually should not be more than 75 RPM.

HIGH RPM MAGNETO CHECKS.

If there is a doubt concerning the operation of the ignition system, RPM checks at higher engine speeds will usually confirm whether a deficiency exists. If a full throttle runup is necessary, the engine should run smoothly and turn approximately 2230 to 2330 RPM with the carburetor heat off.

An absence of RPM drop may be an indication of faulty grounding of one side of the ignition system or should be cause for suspicion that the magneto timing has been "bumped-up" and is set in advance of the set-time specified.

TAKE-OFF.

POWER CHECK.

It is important to check full-throttle engine operation early in the take-off run. Any signs of rough engine operation or sluggish engine acceleration is good cause for discontinuing the take-off. If this occurs, you are justified in making a thorough full-throttle, static runup before another take-off is attempted.

Full-throttle runups over loose gravel are especially harmful to propeller tips. When take-offs must be made over a gravel surface, it is very important that the throttle be advanced slowly. This allows the airplane to start rolling before high RPM is developed, and the gravel will be blown back of the propeller rather than pulled into it. When unavoidable small dents appear in the propeller blades, they should be immediately corrected as described in Section IV under propeller care.

Prior to take-off from fields above 5000 feet elevation, the mixture should be leaned to give maximum RPM in a full-throttle, static runup.

WING FLAP SETTINGS.

Normal and obstacle clearance take-offs are performed with wing flaps up. The use of 10° flaps will shorten the ground run approximately 10%, but this advantage is lost in the climb to a 50-foot obstacle. Therefore, the use of 10° flap is reserved for minimum ground runs or for take-off from soft or rough fields with no obstacles ahead.

If 10° of flaps are used in ground runs, it is preferable to leave them extended rather than retract them in the climb to the obstacle. The exception to this rule would be in a high altitude take-off in hot weather where climb would be marginal with flaps 10°.

Flap deflections of 30° to 40° are not recommended at any time for take-off.

PERFORMANCE CHARTS.

Consult the take-off chart in Section V for take-off distances under various gross weight, altitude, and headwind conditions.

CROSSWIND TAKE-OFFS.

Take-offs into strong crosswinds normally are performed with the minimum flap setting necessary for the field length, to minimize the drift angle immediately after take-off. The airplane is accelerated to a speed slightly higher than normal, then pulled off abruptly to prevent possible settling back to the runway while drifting. When clear of the ground, make a coordinated turn into the wind to correct for drift.

CLIMB.

CLIMB DATA.

For detailed data, refer to the Maximum Rate-of-Climb Data chart in Section V.

CLIMB SPEEDS.

Normal climbs are performed at 80 to 90 MPH with flaps up and full throttle for best engine cooling. The mixture should be full rich unless the engine is rough due to too rich a mixture. The best rate-of-climb speeds range from 80 MPH at sea level to 77 MPH at 10,000 feet. If an obstacle dictates the use of a steep climb angle, the best angle-of-climb speed should be used with flaps up and full throttle. These speeds vary from 65 MPH at sea level to 71 MPH at 10,000 feet.

NOTE

Steep climbs at these low speeds should be of short duration to improve engine cooling.

GO-AROUND CLIMB.

In a balked landing (go-around) climb, the wing flap setting should be reduced to 20° immediately after full power is applied. Upon reaching a safe airspeed, the flaps should be slowly retracted to the full up position.

CRUISE.

Normal cruising is done between 65% and 75% power. The power

settings required to obtain these powers at various altitudes and outside air temperatures can be determined by using your Cessna Power Computer.

Cruising can be done most efficiently at high altitudes because of lower air density and therefore lower airplane drag. This is illustrated in the following table which shows performance at 75% power at various altitudes.

OPTIMUM CRUISE PERFORMANCE

ALTITUDE	RPM	TRUE AIRSPEED	RANGE
Sea Level	2450	123	520
5000 ft.	2560	128	540
7000 ft.	Full Throttle	130	550

All figures are based on lean mixture, 36 gallons of fuel (no reserve), zero wind, standard atmospheric conditions, and 2300 pounds gross weight.

STALLS.

The stall characteristics are conventional and aural warning is provided by a stall warning horn which sounds between 5 and 10 MPH above the stall in all configurations.

Power-off stall speeds at maximum gross weight and aft c. g. condition are presented on page 5-2 as calibrated airspeeds since indicated airspeeds are unreliable near the stall.

LANDING.

Normal landings are made power-off with any flap setting. Slips are prohibited in full flap approaches because of a downward pitch encountered under certain combinations of airspeed and sideslip angle.

SHORT FIELD LANDINGS.

For a short field landing, make a power-off approach at approximately 67 MPH with flaps 40°, and land on the main wheels first. Immediately after touchdown, lower the nose gear to the ground and apply heavy braking as required. Raising the flaps after landing will provide more efficient braking.

CROSSWIND LANDINGS.

When landing in a strong crosswind, use the minimum flap setting required for the field length. Use a wing-low, crab, or a combination method of drift correction and land in a nearly level attitude. Hold a straight course with the steerable nosewheel and occasional braking if necessary.

COLD WEATHER OPERATION.

Prior to starting on cold morning, it is advisable to pull the propeller through several times by hand to "break loose" or "limber" the oil, thus conserving battery energy. In extremely cold (0° F and lower) weather, the use of an external preheater for both the engine and battery is recommended whenever possible to reduce wear and abuse to the engine and the electrical system. When using an external power source, the position of the master switch is important. Refer to Section VI, GROUND SERVICE PLUG RECEPTACLE, for operating details. Cold weather starting procedures are as follows:

With Preheat:

- (1) Clear propeller.
- (2) Pull master switch "ON."
- (3) With magneto switch "OFF" and throttle closed, prime the engine four to ten strokes as the engine is being turned over.

NOTE

Use heavy strokes of primer for best atomization of fuel. After priming, push primer all the way in and turn to locked position to avoid possibility of engine drawing fuel through the primer.

- (4) Turn magneto switch to "BOTH."
- (5) Open throttle 1/4" and engage starter.

Without Preheat:

- (1) Prime the engine 8 to 10 strokes while the propeller is being turned by hand.
- (2) Clear propeller.
- (3) Pull master switch "ON."
- (4) Turn magneto switch to "BOTH."
- (5) Open throttle 1/4".
- (6) Pull carburetor air heat knob full on.
- (7) Engage starter and continue to prime engine until it is running smoothly.
- (8) Keep carburetor heat on until engine has warmed up.

NOTE

If the engine does not start the first time, it is probable that the spark plugs have been frosted over. Preheat must be used before another start is attempted.

During cold weather operations, no indication will be apparent on the oil temperature gage prior to take-off if outside air temperatures are very cold. After a suitable warm-up period (2 to 5 minutes at 1000 RPM), accelerate the engine several times to higher engine RPM. If the engine accelerates smoothly and the oil pressure remains normal and steady, the airplane is ready for take-off.

When operating in sub-zero temperature, avoid using partial carburetor heat. Partial heat may increase the carburetor air temperature to the 32° to 80° F range, where icing is critical under certain atmospheric conditions.

Refer to Section VI for cold weather equipment.



MODIFIED FUEL MANAGEMENT PROCEDURES

With a combination of highly volatile fuel, high fuel temperature, high operating altitude, and low fuel flow rate in the tank outlet lines, there is a remote possibility of accumulating fuel vapor and encountering power irregularities on some airplanes. To minimize this possibility, the following operating procedures are recommended:

- (1) Take-off and climb to cruise altitude on "both" tanks.
(This is consistent with current recommendations.)
- (2) When reaching cruise altitude above 5000 feet MSL, promptly switch the fuel selector valve from "both" tanks to either the "right" or "left" tank.
- (3) During cruise, use "left" and "right" tank as required.
- (4) Select "both" tanks for landing as currently recommended.

POWER RECOVERY TECHNIQUES

In the remote event that vapor is present in sufficient amounts to cause a power irregularity, the following power recovery techniques should be followed:

OPERATION ON A SINGLE TANK

Should power irregularities occur when operating on a single tank, power can be restored immediately by switching to the opposite tank. In addition, the vapor accumulation in the tank on which the power irregularity occurred will rapidly dissipate itself such that that tank will also be available for normal operation after it has been unused for approximately one (1) minute.

OPERATION ON BOTH TANKS

Should power irregularities occur with the fuel selector on both tanks, the following steps are to be taken to restore power:

- (1) Switch to a single tank for a period of 60 seconds.
- (2) Then switch to the opposite tank and power will be restored.

OPERATING LIMITATIONS

OPERATIONS AUTHORIZED.

Your Cessna exceeds the requirements of airworthiness as set forth by the United States Government, and is certificated under FAA Type Certificate No. 3A12 as Cessna Model No. 172F.

With standard equipment, the airplane is approved for day and night operations under VFR. Additional optional equipment is available to increase its utility and to make it authorized for use under IFR day and night. An owner of a properly equipped Cessna is eligible to obtain approval for its operation on single-engine scheduled airline service under VFR. Your Cessna Dealer will be happy to assist you in selecting equipment best suited to your needs.

MANEUVERS - NORMAL CATEGORY.

The airplane exceeds the requirements for airworthiness of the Federal Air Regulations, Part 3, set forth by the United States Government. Spins and aerobatic maneuvers are not permitted in normal category airplanes in compliance with these regulations. In connection with the foregoing, the following gross weights and flight load factors apply:

Gross Weight	2300 lbs.
Flight Load Factor *Flaps Up	+3.8 -1.52
Flight Load Factor *Flaps Down	+3.5

*The design load factors are 150% of the above, and in all cases, the structure meets or exceeds design loads.

Your airplane must be operated in accordance with all FAA approved markings, placards and check lists in the airplane. If there is any information in this section which contradicts the FAA approved markings, placards and check lists, it is to be disregarded.

WEIGHT AND BALANCE.

The following information will enable you to operate your Cessna within the prescribed weight and center of gravity limitations. To figure the weight and balance for your particular airplane, use the Sample Problem, Loading Graph, and Center of Gravity Moment Envelope as follows:

Take the licensed Empty Weight and Moment/1000 from the Weight and Balance Data sheet, plus any changes noted on forms FAA-337, carried in your airplane, and write them down in the proper columns. Using the Loading Graph, determine the moment/1000 of each item to be carried. Total the weights and moments/1000 and use the Center of Gravity Moment Envelope to determine whether the point falls within the envelope, and if the loading is acceptable.

SAMPLE AIRPLANE		YOUR AIRPLANE	
Weight (lbs)	Moment (lb. ins. /1000)	Weight	Moment
1324	48.2		
15	-0.3	15	-0.3
340	12.2		
216	10.4		
340	23.8		
65	6.2		
2300	100.5		

172

SAMPLE LOADING PROBLEM

- Licensed Empty Weight (Sample Airplane) ...
- Oil - 8 Qts.*
- Pilot & Front Passenger
- Fuel. (36 Gal at 6#/ Gal)
- Rear Passengers
- Baggage (or Passenger on Auxiliary Seat)
- Total Aircraft Weight (Loaded)

8. Locate this point (2300 at 100.5) on the center of gravity envelope, and since this point falls within the envelope the loading is acceptable.

*Note: Normally full oil may be assumed for all flights.

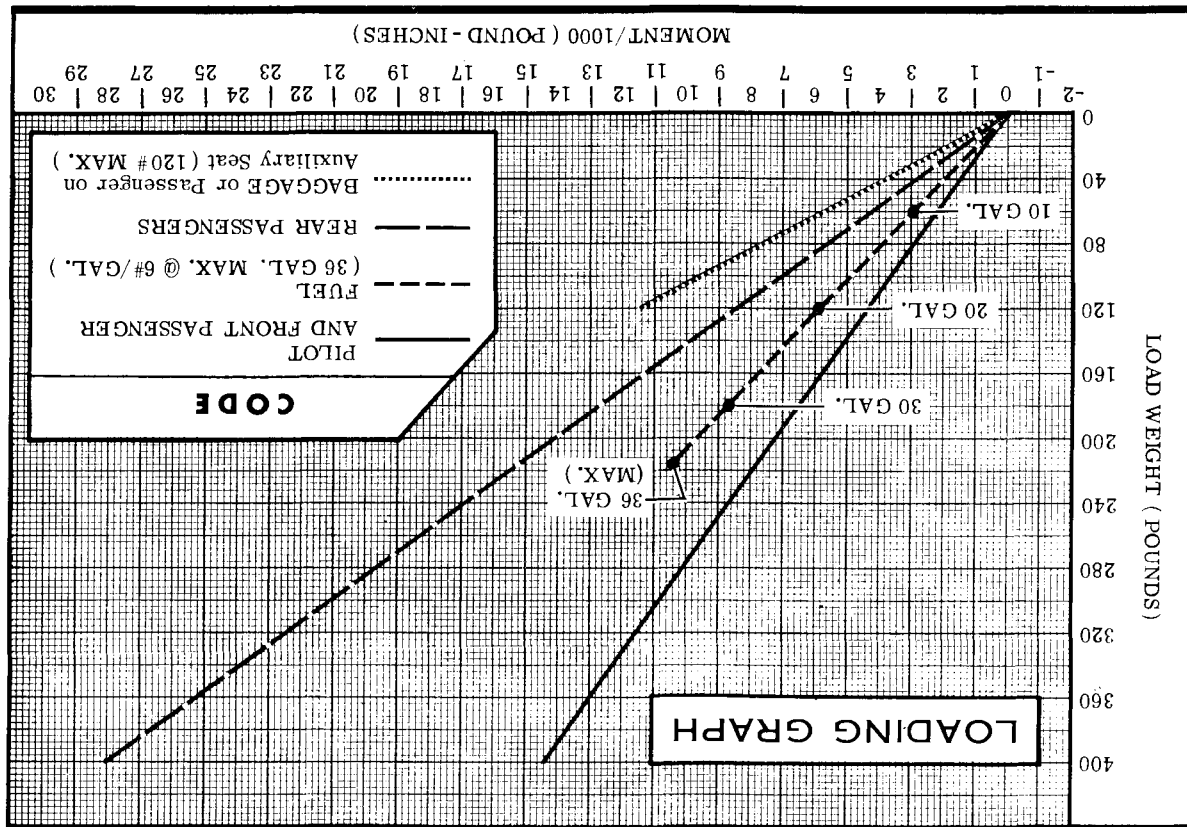

172 **Section IV**

CARE OF THE AIRPLANE

If your airplane is to retain that new plane performance and dependability, certain inspection and maintenance requirements must be followed. It is wise to follow a planned schedule of lubrication and preventative maintenance based on climatic and flying conditions encountered in your locality.

Keep in touch with your Cessna Dealer and take advantage of his knowledge and experience. He knows your airplane and how to maintain it. He will remind you when lubrications and oil changes are necessary, and about other seasonal and periodic services.

GROUND HANDLING.

The airplane is most easily and safely maneuvered by hand with the tow-bar attached to the nosewheel.

NOTE

When using the tow-bar, never exceed the turning angle of 30°, either side of center, or damage to the gear will result.

MOORING YOUR AIRPLANE.

Proper tie-down procedure is your best precaution against damage to your parked airplane by gusty or strong winds. To tie-down your airplane securely, proceed as follows:

- (1) Set the parking brake and install the control wheel lock.
- (2) Tie sufficiently strong ropes or chains (700 pounds tensile strength) to wing, tail, and nose tie-down fittings and secure each rope to a ramp tie-down.

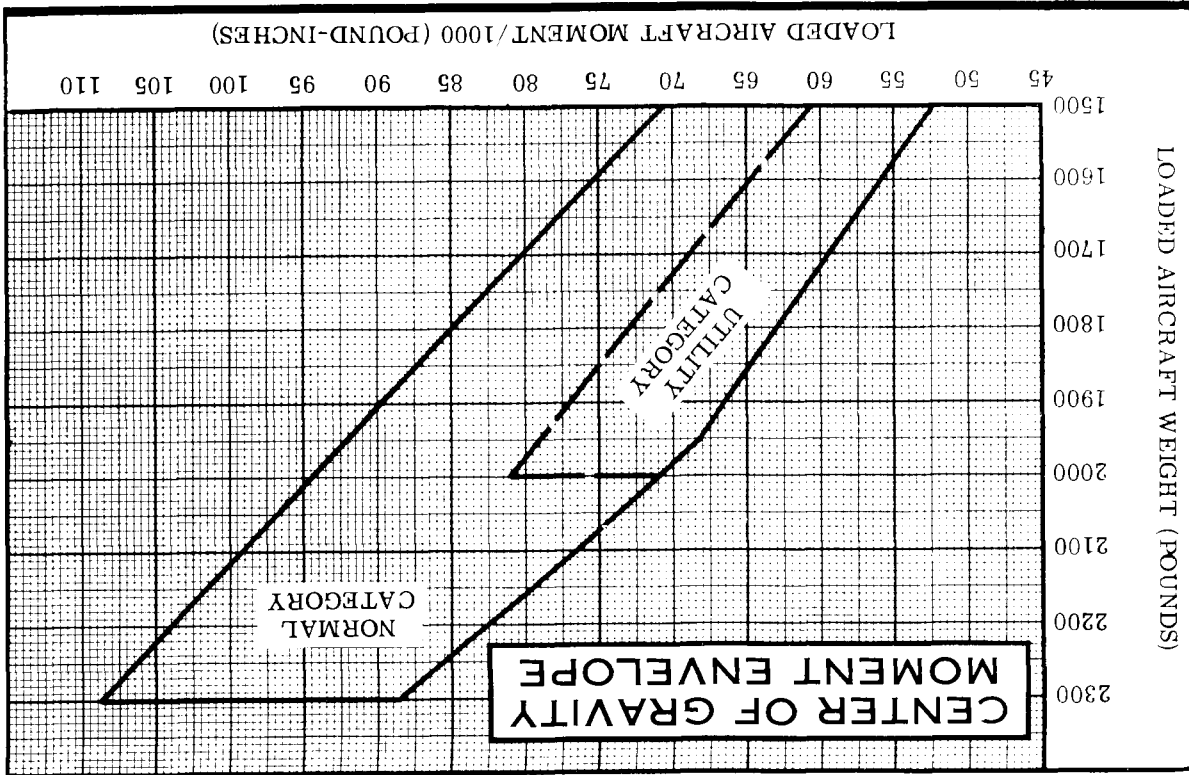

- (3) Install a surface control lock over the fin and rudder.
- (4) Install a pitot tube cover.

WINDSHIELD - WINDOWS.

The plastic windshield and windows should be kept clean and waxed at all times. To prevent scratches and crazing, wash them carefully with plenty of soap and water, using the palm of the hand to feel and dislodge dirt and mud. A soft cloth, chamois or sponge may be used, but only to carry water to the surface. Rinse thoroughly, then dry with a clean, moist chamois. Rubbing the surface of the plastic with a dry cloth builds up an electrostatic charge so that it attracts dust particles in the air. Wiping with a moist chamois will remove both the dust and this charge.

Remove oil and grease with a cloth moistened with kerosene. Never use gasoline, benzine, alcohol, acetone, carbon tetrachloride, fire extinguisher or anti-ice fluid, lacquer thinner or glass cleaner. These materials will soften the plastic and may cause it to craze.

After removing dirt and grease, if the surface is not badly scratched, it should be waxed with a good grade of commercial wax. The wax will fill in minor scratches and help prevent further scratching. Apply a thin, even coat of wax, and bring it to a high polish by rubbing lightly with a clean, dry, soft flannel cloth. Do not use a power buffer; the heat generated by the buffing pad may soften the plastic.

Do not use a canvas cover on the windshield unless freezing rain or sleet is anticipated. Canvas covers may scratch the plastic surface.

PAINTED SURFACES.

The painted exterior surfaces of your new Cessna require an initial curing period which may be as long as 90 days after the finish is applied. During this curing period some precautions should be taken to avoid damaging the finish or interfering with the curing process. The finish should be cleaned only by washing with clean water and mild soap, followed by a rinse with water and drying with cloths or a chamois. Do not use polish or wax, which would exclude air from the surface, during this 90-day curing period. Do not rub or buff the finish, and avoid flying through rain, hail or sleet.

Once the finish has cured completely, it may be waxed with a good

automotive wax. A heavier coating of wax on the leading edges of the wings and tail and on the engine nose cap and propeller spinner will help reduce the abrasion encountered in these areas.

ALUMINUM SURFACES.

The clad aluminum surfaces of your Cessna may be washed with clear water to remove dirt; oil and grease may be removed with gasoline, naphtha, carbon tetrachloride or other non-alkaline solvents. Dull aluminum surfaces may be cleaned effectively with an aircraft aluminum polish.

After cleaning, and periodically thereafter, waxing with a good automotive wax will preserve the bright appearance and retard corrosion. Regular waxing is especially recommended for airplanes operated in salt water areas as a protection against corrosion.

PROPELLER CARE.

Preflight inspection of propeller blades for nicks, and wiping them occasionally with an oily cloth to clean off grass and bug stains will assure long, trouble-free service. It is vital that small nicks on the propellers, particularly near the tips and on the leading edges, are dressed out as soon as possible since these nicks produce stress concentrations, and if ignored, may result in cracks. Never use an alkaline cleaner on the blades; remove grease and dirt with carbon tetrachloride or Stoddard solvent.

INTERIOR CARE.

To remove dust and loose dirt from the upholstery and carpet, clean the interior regularly with a vacuum cleaner.

Blot up any spilled liquid promptly, with cleansing tissue or rags. Don't pat the spot; press the blotting material firmly and hold it for several seconds. Continue blotting until no more liquid is taken up. Scrape off sticky materials with a dull knife, then spot-clean the area.

Oily spots may be cleaned with household spot removers, used sparingly. Before using any solvent, read the instructions on the container

and test it on an obscure place on the fabric to be cleaned. Never saturate the fabric with a volatile solvent; it may damage the padding and backing materials.

Soiled upholstery and carpet may be cleaned with foam-type detergent, used according to the manufacturer's instructions. To minimize wetting the fabric, keep the foam as dry as possible and remove it with a vacuum cleaner.

The plastic trim, headliner, instrument panel and control knobs need only be wiped off with a damp cloth. Oil and grease on the control wheel and control knobs can be removed with a cloth moistened with kerosene. Volatile solvents, such as mentioned in paragraphs on care of the windshield, must never be used since they soften and craze the plastic.

INSPECTION SERVICE AND INSPECTION PERIODS.

With your airplane you will receive an Owner's Service Policy. Coupons attached to the policy entitle you to an initial inspection and the first 100-hour inspection at no charge. If you take delivery from your Dealer, he will perform the initial inspection before delivery of the airplane to you. If you pick up the airplane at the factory, plan to take it to your Dealer reasonably soon after you take delivery on it. This will permit him to check it over and to make any minor adjustments that may appear necessary. Also, plan an inspection by your Dealer at 100 hours or 180 days, whichever comes first. This inspection also is performed by your Dealer for you at no charge. While these important inspections will be performed for you by any Cessna Dealer, in most cases you will prefer to have the Dealer from whom you purchased the airplane accomplish this work.

Federal Air Regulations require that all airplanes have a periodic (annual) inspection as prescribed by the administrator, and performed by a person designated by the administrator. In addition, 100-hour periodic inspections made by an "appropriately-rated mechanic" are required if the airplane is flown for hire. The Cessna Aircraft Company recommends the 100-hour periodic inspection for your airplane. The procedure for this 100-hour inspection has been carefully worked out by the factory and is followed by the Cessna Dealer Organization. The complete familiarity of the Cessna Dealer Organization with Cessna equipment and with factory-approved procedures provides the highest type of service possible at lower cost.

AIRPLANE FILE.

There are miscellaneous data, information and licenses that are a part of the airplane file. The following is a check list for that file. In addition, a periodic check should be made of the latest Federal Air Regulations to insure that all data requirements are met.

- A. To be displayed in the airplane at all times:
 - (1) Aircraft Airworthiness Certificate (Form FAA-1362).
 - (2) Aircraft Registration Certificate (Form FAA-500A).
 - (3) Airplane Radio Station License (Form FCC-404, if transmitter installed).
- B. To be carried in the airplane at all times:
 - (1) Weight and Balance, and associated papers (latest copy of the Repair and Alteration Form, Form FAA-337, if applicable).
 - (2) Airplane Equipment List.
- C. To be made available upon request:
 - (1) Airplane Log Book.
 - (2) Engine Log Book.

NOTE

Cessna recommends that these items, plus the Owner's Manual and the "Cessna Flight Guide" (Flight Computer), be carried in the airplane at all times.

Most of the items listed are required by the United States Federal Air Regulations. Since the regulations of other nations may require other documents and data, owners of exported airplanes should check with their own aviation officials to determine their individual requirements.

LUBRICATION AND SERVICING PROCEDURES

Specific servicing information is provided here for items requiring daily attention. A Servicing Intervals Check List is included to inform the pilot when to have other items checked and serviced.

DAILY

FUEL TANK FILLERS:

Service after each flight with 80/87 minimum grade fuel. The capacity of each wing tank is 19.5 gallons.

FUEL STRAINER:

On the first flight of the day and after each refueling, pull out fuel strainer drain knob for about four seconds, to clear fuel strainer of possible water and sediment. Release drain knob, then check that strainer drain is closed after draining.

OIL FILLER:

When preflight check shows low oil level, service with aviation grade engine oil; SAE 20 below 40°F. and SAE 40 above 40°F. Your Cessna was delivered from the factory with straight mineral oil (non-detergent) and should be operated with straight mineral oil for the first 25 hours. The use of mineral oil during the 25-hour break-in period will help seat the piston rings and will result in less oil consumption. After the first 25 hours, either mineral oil or detergent oil may be used. If a detergent oil is used, it must conform to Continental Motors Corporation Specification MHS-24. Your Cessna Dealer can supply an approved brand.

OIL DIPSTICK:

Check oil level before each flight. Do not operate on less than 6 quarts. To minimize loss of oil through breather, fill to 7 quart level for normal flights of less than 3 hours. For extended flight, fill to 8 quarts. If optional oil filter is installed, one additional quart is required when the filter element is changed.

SERVICING INTERVALS CHECK LIST

EACH 50 HOURS

BATTERY -- Check and service. Check oftener (at least every 30 days) if operating in hot weather.

ENGINE OIL AND OIL FILTER -- Change engine oil and replace filter element. If optional oil filter is not installed, change oil and clean screen every 25 hours. Change engine oil at least every four months even though less than 50 hours have been accumulated. Reduce periods for prolonged operation in dusty areas, cold climates, or when short flights and long idle periods result in sludging conditions.

CARBURETOR AIR FILTER -- Clean or replace. Under extremely dusty conditions, daily maintenance of the filter is recommended.

NOSE GEAR TORQUE LINKS -- Lubricate.

EACH 100 HOURS

BRAKE MASTER CYLINDERS -- Check and fill.

SHIMMY DAMPENER -- Check and fill.

FUEL STRAINER -- Disassemble and clean.

FUEL TANK SUMP DRAINS -- Drain water and sediment.

FUEL LINE DRAIN PLUG -- Drain water and sediment.

VACUUM SYSTEM OIL SEPARATOR (OPT) -- Clean.

SUCTION RELIEF VALVE INLET SCREEN (OPT) -- Clean.

EACH 500 HOURS

VACUUM SYSTEM AIR FILTER (OPT) -- Replace filter element. Replace sooner if suction gage reading drops below 3.75 in. Hg.

WHEEL BEARINGS -- Lubricate. Lubricate at first 100 hours and at 500 hours thereafter.

AS REQUIRED

NOSE GEAR SHOCK STRUT -- Keep inflated and filled.

GYRO INSTRUMENT AIR FILTERS (OPT) -- Replace at instrument overhaul.

Section 172

OPERATIONAL DATA

The operational data shown on the following pages are compiled from actual tests with airplane and engine in good condition and using average piloting technique and best power mixture. You will find this data a valuable aid when planning your flights. However, inasmuch as the number of variables included precludes great accuracy, an ample fuel reserve should be provided. The range performance shown makes no allowance for wind, navigational error, pilot technique, warm-up, take-off, climb, etc. All of these factors must be considered when estimating reserve fuel.

A power setting selected from the range charts usually will be more efficient than a random setting, since it will permit you to estimate your fuel consumption more accurately. You will find that using the charts and your Power Computer will pay dividends in overall efficiency.

Range and endurance figures shown in the charts are based on flight test using McCauley 1C172/EM 7653 propeller. Other conditions of the tests are shown in the chart headings. Allowances for fuel reserve, headwinds, take-offs, and climb, and variations in mixture leaning technique should be made and are in addition to those shown on the charts. Other indeterminate variables such as carburetor metering-characteristics engine and propeller conditions, and turbulence of atmosphere may account for variations of 10% or more in maximum range.

OWNER FOLLOW-UP SYSTEM



172

Your Cessna Dealer has an owner follow-up system to notify you when he receives information that applies to your Cessna. In addition, if you wish, you may choose to receive similar notification directly from the Cessna Service Department. A subscription card is supplied in your airplane file for your use, should you choose to request this service. Your Cessna Dealer will be glad to supply you with details concerning these follow-up programs, and stands ready through his Service Department to supply you with fast, efficient, low cost service.



AIRSPEED CORRECTION TABLE												
FLAPS	IAS											
	40	50	60	70	80	90	100	110	120	130	140	
FLAPS UP	CAS	55	60	66	72	80	89	98	108	117	127	136
	CAS	52	58	65	73	82	91	101	•	•	•	•
FLAPS DOWN	CAS	52	58	65	73	82	91	101	•	•	•	•

Figure 5-1.

POWER OFF STALLING SPEEDS MPH - CAS												
2300 LBS. GROSS WEIGHT	CONDITION											
	FLAPS UP			FLAPS 10°			FLAPS 40°			ANGLE OF BANK		
				0°	20°	40°	60°					
				57	59	65	81					
				52	54	59	74					
				49	51	56	69					

Figure 5-2.

TAKE-OFF DATA										
TAKE-OFF DISTANCE FROM HARD SURFACE RUNWAY, FLAPS UP										
GROSS WEIGHT LBS.	IAS AT 50 FT. MPH	HEAD WIND KNOTS	@ S.L. & 59° F		@ 2500 ft. & 50° F		@ 5000 ft. & 41° F		@ 7500 ft. & 32° F	
			GROUND RUN	TOTAL TO CLEAR 50' OBS.	GROUND RUN	TOTAL TO CLEAR 50' OBS.	GROUND RUN	TOTAL TO CLEAR 50' OBS.	GROUND RUN	TOTAL TO CLEAR 50' OBS.
1700	60	0	435	780	520	920	625	1095	765	1370
		10	290	570	355	680	430	820	535	1040
		20	175	385	215	470	270	575	345	745
2000	65	0	630	1095	755	1325	905	1625	1120	2155
		10	435	820	530	1005	645	1250	810	1685
		20	275	580	340	720	425	910	595	1255
2300	70	0	865	1525	1040	1910	1255	2480	1565	3855
		10	615	1170	750	1485	920	1955	1160	3110
		20	405	850	505	1100	630	1480	810	2425

Note: Increase distance 10% for each 25°F above standard temperature for particular altitude.

MAXIMUM RATE-OF-CLIMB DATA												
GROSS WEIGHT LBS.	@ S.L. & 59° F			@ 5000 ft. & 41° F			@ 10,000 ft. & 23° F			@ 15,000 ft. & 5° F		
	IAS MPH	RATE OF CLIMB FT/MIN.	GALS OF FUEL USED	IAS MPH	RATE OF CLIMB FT/MIN.	FROM S.L. FUEL USED	IAS MPH	RATE OF CLIMB FT/MIN.	FROM S.L. FUEL USED	IAS MPH	RATE OF CLIMB FT/MIN.	FROM S.L. FUEL USED
1700	75	1085	1.0	73	825	1.9	71	570	2.9	70	315	4.4
2000	77	840	1.0	76	610	2.2	74	380	3.6	73	155	6.3
2300	80	645	1.0	78	435	2.6	77	230	4.8	76	22	11.5

Note: Flaps up, full throttle and mixture leaned for smooth operation above 5000 ft. Fuel used includes warm-up and take-off allowance.

Figure 5-3.

CRUISE & RANGE PERFORMANCE 172 SKYHAWK							Gross Weight- 2300 Lbs.* Standard Conditions * Zero Wind*Lean Mixture * 36 Gal. of Fuel (No Reserve)
NOTE: Maximum cruise is normally limited to 75% power. For standard 172 performance, subtract 1 MPH from the higher cruise speeds shown.							
ALT.	RPM	% BHP	TAS MPH	GAL. / HOUR	ENDR. HOURS	RANGE MILES	
5000	2700	87	136	9.8	3.7	500	
	2600	78	130	8.8	4.1	525	
	2550	74	127	8.4	4.3	550	
	2500	70	124	7.9	4.5	560	
	2400	62	118	7.1	5.1	600	
7500	2300	55	111	6.4	5.6	625	
	2200	49	105	5.9	6.1	640	
	2100	44	98	5.5	6.4	640	
	2650	77	132	8.7	4.2	550	
	2600	73	129	8.2	4.3	560	
10,000	2500	65	123	7.4	4.9	600	
	2400	58	116	6.7	5.3	620	
	2300	52	110	6.1	5.9	650	
	2200	47	103	5.7	6.4	655	
	2100	42	97	5.3	6.7	655	
12,500	2600	68	128	7.7	4.7	605	
	2500	61	121	7.0	5.2	625	
	2400	55	115	6.4	5.6	645	
	2300	49	108	5.9	6.1	655	
	2200	45	102	5.5	6.6	670	
12,500	2600	63	126	7.2	5.0	630	
	2500	57	120	6.6	5.4	650	
	2400	52	113	6.1	5.9	670	
	2300	47	107	5.7	6.3	670	
	2200	43	101	5.4	6.6	670	

Figure 5-4.

LANDING DATA									
LANDING DISTANCE ON HARD SURFACE RUNWAY									
NO WIND - 40° FLAPS - POWER OFF									
GROSS WEIGHT LBS.	APPROACH IAS MPH	@ S.L. & 59° F		@ 2500 ft. & 50° F		@ 5000 ft. & 41° F		@ 7500 ft. & 32° F	
		GROUND ROLL	TOTAL TO CLEAR 50' OBS.	GROUND ROLL	TOTAL TO CLEAR 50' OBS.	GROUND ROLL	TOTAL TO CLEAR 50' OBS.	GROUND ROLL	TOTAL TO CLEAR 50' OBS.
2300	65	520	1250	560	1310	605	1385	650	1455

Note: Reduce landing distance 10% for each 5 knot headwind.

Figure 5-5.

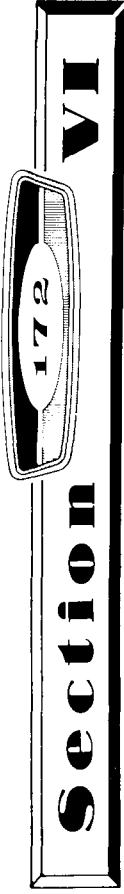

OPTIONAL SYSTEMS

This section contains a description, operating procedures, and performance data (when applicable) for some of the optional equipment which may be installed in your Cessna. Owner's Manual Supplements are provided to cover operation of other optional equipment systems when installed in your airplane. Contact your Cessna Dealer for a complete list of available optional equipment.

AUXILIARY FUEL TANK SYSTEM

An optional auxiliary fuel tank system (figure 6-1) is available to increase the airplane operating range. System components include an 18 gallon fuel tank (17.55 gallons usable) installed on the baggage compartment floor; an electric fuel transfer pump behind the tank, an electrical-ly-operated fuel quantity indicator and fuel transfer pump switch on the instrument panel; a fuel tank filler provision on the right side of the fuselage; a fuel tank sump drain valve at the front of the tank on the bottom of the fuselage, and the necessary plumbing.

The auxiliary fuel system is connected to the right main fuel tank plumbing above the right cabin door.

AUXILIARY FUEL SYSTEM OPERATION.

To operate the auxiliary fuel system, proceed as follows:

PRE-FLIGHT CHECK:

- (1) Turn on master switch and check fuel quantity indicator for reading.

- (2) Momentarily pull on transfer pump switch and listen for pump operation. Turn off master switch.
- (3) Check quantity of fuel in tank for agreement with fuel quantity indicator. Fill tank for anticipated requirements.
- (4) Drain small amount of fuel from fuel tank drain valve to check for possible water and sediment.

DURING FLIGHT:

- (1) Take-off, climb and land with fuel selector valve handle set on "BOTH" for maximum safety.
- (2) After leveling off at cruise altitude, switch to "RIGHT" and operate from this tank until the fuel supply is exhausted.
- (3) Switch to "LEFT" for operation, then pull on transfer pump switch and refill main fuel tank from auxiliary tank. Push transfer pump switch off when fuel transfer is completed.

NOTE

Transfer of total fuel from the auxiliary tank will take from 45 minutes to 1 hour.

- (4) Return fuel selector valve handle to "BOTH" position after refilling right tank, or if desired switch again to right main tank.

IMPORTANT

Do not operate the transfer pump with the fuel selector turned to either "BOTH" or "RIGHT" positions. Total or partial engine stoppage will result from air being pumped into fuel lines after fuel transfer has been completed. If the pump should accidentally be turned on with the fuel selector in either of these positions, and engine stoppage occurs, the engine will restart in from 3 to 5 seconds after turning off the transfer pump as the air in the fuel line will be evacuated rapidly.

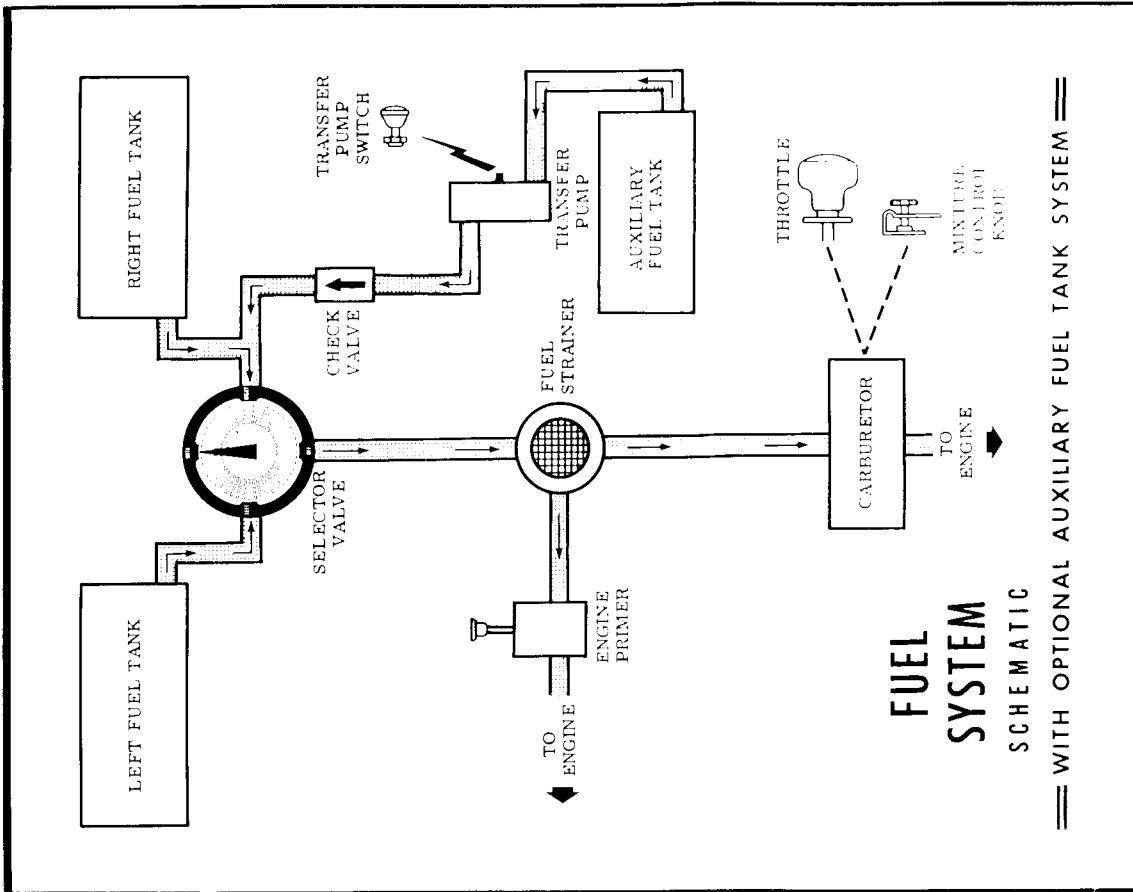

Figure 6-1.

COLD WEATHER EQUIPMENT

WINTERIZATION KIT.

For continuous operation in temperatures consistently below 20° F, the Cessna winterization kit, available from your Cessna Dealer, should be installed to improve engine operation.

GROUND SERVICE PLUG RECEPTACLE.

A ground service plug receptacle may be installed to permit the use of an external power source for cold weather starting and during lengthy maintenance work on the electrical system.

When using a battery type cart as an external power source for starting the engine, the master switch should be turned off. This prevents a low airplane battery from draining the limited external power available from a battery cart. If a generator type external power source is used for starting, the master switch may be turned off or on, as desired by the pilot.

RADIO SELECTOR SWITCHES

RADIO SELECTOR SWITCH OPERATION.

Operation of the radio equipment is normal as covered in the respective radio manuals. When more than one radio is installed, an audio switching system is necessary. The operation of this switching system is described below.

TRANSMITTER SELECTOR SWITCH.

The transmitter selector switch (figure 6-2) is labeled "TRANS," and has two positions. When two transmitters are installed, it is nec-

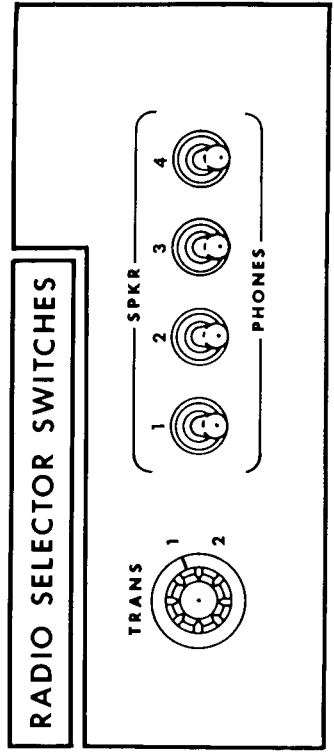

Figure 6-2.

essary to switch the microphone to the radio unit the pilot desires to use for transmission. This is accomplished by placing the transmitter selector switch in the position corresponding to the radio unit which is to be used.

SPEAKER-PHONE SWITCHES.

The speaker-phone switches (figure 6-2) determine whether the output of the receiver in use is fed to the headphones or through the audio amplifier to the speaker. Place the switch for the desired receiving system either in the up position for speaker operation or in the down position for headphones.

AUTOPILOT-OMNI SWITCH.

When a Nav-O-Matic autopilot is installed with two compatible omni receivers, an autopilot-omni switch is utilized. This switch selects the omni receiver to be used for the omni course sensing function of the autopilot. The switch is mounted just to the right of the autopilot control unit at the bottom of the instrument panel. The switch positions, labeled "OMNI 1" and "OMNI 2", correspond to the omni receivers in the radio panel stack.

ALPHABETICAL INDEX

A

After Landing, 1-4
Air Filter, Carburetor, 4-7
Airplane,
 before entering, 1-1
 care, 4-2, 4-3
 file, 4-5
 ground handling, 4-1
 inspection service-periods, 4-4
 lubrication and servicing, 4-6, 4-7
 mooring, 4-1
Airspeed Correction Table, 5-2
Airspeed Limitations, 3-2
Aluminum Surfaces, 4-3
Authorized Operations, 3-1
Auxiliary Fuel Tank System, 6-1
 operation, 6-1
 schematic, 6-2

B

Baggage, Weight, inside front cover
Battery, 4-7
Beacon, Rotating, 2-3
Before Entering Airplane, 1-1
Before Landing, 1-4
Before Starting Engine, 1-1
Before Take-off, 1-2, 2-6
 magneto checks, 2-6
 warm-up, 2-6
Brake Master Cylinders, 4-7

C

Cabin Heating and Ventilating System, 2-4

Capacity,
 fuel, inside covers, 2-1
 oil, inside covers
Carburetor, 2-2, 6-2
 air filter, 4-7
Care,
 exterior, 4-2, 4-3
 interior, 4-3
 propeller, 4-3
Center of Gravity Moment Envelope, 3-6
Circuit Breakers, 2-3
Climb, 1-3, 2-8
 data, 2-8, 5-3
 go-around climb, 2-8
 maximum performance, 1-3
 normal, 1-3
 speeds, 2-8
Cold Weather Equipment, 6-4
 ground service receptacle, 6-4
 winterization kit, 6-4
Cold Weather Operation, 2-10
Correction Table, Airspeed, 5-2
Crosswind Landing, 2-10
Cruise - Range Performance, 5-4
Cruising, 1-3, 2-8

D

Data,
 climb, 2-8, 5-3
 fuel quantity, 2-1
 landing, 5-5
 take-off, 5-3
Diagram,
 exterior inspection, iv
 principal dimensions, ii
 taxiing, 2-5

Dimensions, Principal, ii
Drain Knob, Fuel Strainer, 2-3
Drain Plug, Fuel Line, 4-7
Drain Plugs, Fuel Tank, 4-7

E

Electrical System, 2-3
battery, 4-7
circuit breakers, 2-3
generator warning light, 2-3
ground service plug
receptacle, 6-4
landing lights, 2-3
rotating beacon, 2-3
Empty Weight, inside front cover
Engine, inside front cover
before starting, 1-1
instrument markings, 3-3
oil screen, 4-7
operation limitations, 3-3
primer, 2-2, 6-2
starting, 1-2, 2-4
Envelope, Weight and Balance, 3-6
Equipment, Cold Weather, 6-4
Exterior Inspection Diagram, iv

primer, 2-2, 6-2
quantity data, 2-1
schematics, 2-2, 6-2
selector valve, 2-2, 6-2
strainer drain knob, 2-3
strainer, 2-2, 4-6, 4-7, 6-2
tank fillers, 4-6
throttle, 2-2, 6-2
transfer pump (auxiliary fuel),
6-2
transfer pump switch, 6-2

G

Generator Warning Light, 2-3
Go-Around Climb, 2-8
Gross Weight, inside front cover
Ground Handling, 4-1
Ground Service Receptacle, 6-4
Gyro Instrument Air Filters, 4-7

H

Handling Airplane on Ground, 4-1
Heating and Ventilating System,
Cabin, 2-4
Hydraulic Fluid Specification,
inside back cover

I

Inspection Diagram, Exterior, iv
Inspection Service-Periods, 4-4
Instrument Markings, 3-3
Interior Care, 4-3

L

Landing, inside front cover, 2-9
after, 1-4

before, 1-4
crosswind, 2-10
data, 5-5
lights, 2-3
normal, 1-4
short field, 2-10
Let-Down, 1-3
Light,
generator warning, 2-3
landing, 2-3
rotating beacon, 2-3
Limitations, Airspeed, 3-2
Limitations, Engine Operating, 3-3
Loading Graph, 3-5
Loading Problem, Sample, 3-4
Lubrication and Servicing
Procedures, 4-6

M

Maneuvers, Normal Category, 3-1
Maneuvers, Utility Category, 3-2
Master Cylinders, Brake, 4-7
Maximum Performance Climb, 1-3
Maximum Performance
Take-off, 1-2
Maximum Rate-of-Climb Data, 5-3
Mixture Control Knob, 2-2, 6-2
Moment Envelope, Center of
Gravity, 3-6
Mooring Your Airplane, 4-1

N

Normal Category, Maneuvers, 3-1
Normal Climb, 1-3
Normal Landing, 1-4
Normal Take-off, 1-2
Nose Gear,
shock strut, 4-7
torque links, 4-7

O

Oil Specification and Grade,
inside back cover
Oil System,
capacity, inside covers
filter, 4-7
oil filler and dipstick, 4-6
Operating Limitations, Engine, 3-3
Operation, Auxiliary Fuel
Tank System, 6-1
Operation, Cold Weather, 2-10
Operations Authorized, 3-1
Optimum Cruise Performance, 2-9
Owner Follow-Up System, 4-8

P

Painted Surfaces, 4-2
Performance, Specifications,
inside front cover
Power Loading, inside front cover
Primer, Engine, 2-2, 6-2
Principal Dimensions, ii
Propeller, inside front cover
care, 4-3

Q

Quantity Data, Fuel, 2-1

R

Radio Selector Switches, 6-4, 6-5
operation, 6-4
speaker-phone switches, 6-5
transmitter selector switch, 6-4
Range, inside front cover
Range - Cruise Performance, 5-4
Rate of Climb, inside front cover
Receptacle, Ground Service, 6-4

S

Sample Loading Problem, 3-4
Schematic, Auxiliary Fuel Tank System, 6-2
Schematic, Fuel System, 2-2
Secure Aircraft, 1-4
Selector Valve, Fuel, 2-2, 6-2
Service Ceiling, inside front cover
Servicing Intervals Check List, 4-7
Servicing Procedures, 4-6
Servicing Requirements Table, inside back cover
Shimmy Dampener, 4-7
Specification and Grade, fuel, inside back cover
hydraulic fluid, inside back cover
oil, inside back cover
Specifications - Performance, inside front cover
Speed, inside front cover
Stalling Speeds Chart, 5-2
Stalls, 2-9
Starting Engine, 1-2, 2-4
Strainer, Fuel, 2-2, 4-6, 4-7, 6-2
Strainer Drain Knob, Fuel, 2-3
Suction Relief Valve Inlet Screen, 4-7

Surfaces,

 painted, 4-2
 aluminum, 4-3
Switches, Radio Selector, 6-4, 6-5

System,

 auxiliary fuel tank, 6-1
 cabin heating and ventilating, 2-4
 electrical, 2-3
 fuel, 2-1
 owner follow-up, 4-8

Take-off, inside front cover, 1-2, 2-7

 before, 1-2, 2-6
 crosswind, 2-8
 data, 5-3
 maximum performance, 1-2
 normal, 1-2
 performance charts, 2-7
 power check, 2-7
 wing flap settings, 2-7
Taxiing, 2-6
 diagram, 2-5
Throttle, 2-2, 6-2
Tire Pressures, inside back cover
Torque Links, Nose Gear, 4-7
Transfer Pump (Auxiliary Fuel), 6-2
Transfer Pump Switch, 6-2

U

Utility Category, Maneuvers, 3-2

V

Vacuum System Oil Separator, 4-7
Valve, Fuel Selector, 2-2, 6-2

W

Warning Light, Generator, 2-3
Weight,
 empty, inside front cover
 gross, inside front cover
Weight and Balance, 3-4
 loading graph, 3-5
 moment envelope, 3-6
 sample loading problem, 3-4
Wheel Bearings, 4-7
Windshield and Windows, 4-2
Wing Loading, inside cover
Winterization Kit, 6-4

T

Table of Contents, iii

Index, 4

SERVICING REQUIREMENTS

FUEL:

AVIATION GRADE -- 80/87 MINIMUM GRADE
CAPACITY EACH TANK -- 19.5 GALLONS

ENGINE OIL:

AVIATION GRADE -- SAE 40 ABOVE 40° F.
SAE 20 BELOW 40° F.

(AIRCRAFT DELIVERED WITH STRAIGHT MINERAL OIL. EITHER MINERAL OIL OR DETERGENT OIL MAY BE USED. IF DETERGENT OIL IS USED, IT MUST CONFORM TO CONTINENTAL MOTORS SPECIFICATION MHS-24.)

CAPACITY OF ENGINE SUMP -- 8 QUARTS

(DO NOT OPERATE ON LESS THAN 6 QUARTS. TO MINIMIZE LOSS OF OIL THROUGH BREATHER, FILL TO 7 QUART LEVEL FOR NORMAL FLIGHTS OF LESS THAN 3 HOURS. FOR EXTENDED FLIGHT, FILL TO 8 QUARTS. IF OPTIONAL OIL FILTER IS INSTALLED, ONE ADDITIONAL QUART IS REQUIRED WHEN THE FILTER ELEMENT IS CHANGED.)

HYDRAULIC FLUID:

MIL.-H-5606 HYDRAULIC FLUID

TIRE PRESSURES:

NOSE WHEEL-----26 PSI ON 5.00x5 TIRE
26 PSI ON 6.00x6 TIRE
MAIN WHEELS-----24 PSI ON 6.00x6 TIRES

WARRANTY

■ The Cessna Aircraft Company (Cessna) warrants each new aircraft, including factory installed equipment and accessories, and warrants all new aircraft equipment and accessories bearing the name "Cessna," to be free from defects in material and workmanship under normal use and service. Cessna's obligation under this warranty is limited to supplying a part or parts to replace any part or parts which, within six (6) months after delivery of such aircraft or such aircraft equipment or accessories to the original retail purchaser or first user, shall be returned transportation charges prepaid to Cessna at Wichita, Kansas, or such other place as Cessna may designate and which upon examination shall disclose to Cessna's satisfaction to have been thus defective.

■ The provisions of this warranty shall not apply to any aircraft, equipment or accessories which have been subject to misuse, negligence or accident, or which shall have been repaired or altered outside of Cessna's factory in any way so as in the judgment of Cessna to affect adversely its performance, stability or reliability. This warranty is expressly in lieu of any other warranties, expressed or implied, including any implied warranty of merchantability or fitness for a particular purpose, and of any other obligation or liability on the part of Cessna of any nature whatsoever and Cessna neither assumes nor authorizes any one to assume for it any other obligation or liability in connection with such aircraft, equipment and accessories.

THERE ARE MORE CESSNAS FLYING THAN ANY OTHER MAKE

1965

CESSNA



MODEL 172 A AND SKYHAWK



TAKE YOUR CESSNA HO
FOR SERVICE AT THE S
OF THE CESSNA SHIELD

CESSNA AIRCRAFT COMPANY

WICHITA, KANSAS

OWNER'S
MANUAL

WORLD'S LARGEST PRODUCER OF GENERAL AVIATION AIRCRAFT SINCE 1956

WEIGHT & BALANCE DATA

WEIGHING PROCEDURE

Scale Position	Scale Reading	Tare	Symbol	Net Weight
Left Wheel	566		L	566
Right Wheel	574		R	574
Nose Wheel	496		N	496
Aircraft Empty Weight (As Weighed)				1636

follow IA304442
11/30/07

$$X = \text{ARM} = (A) - (N) \times (B) / W$$

$$X = (54.75) - (496) \times (65.5) / 1636 = (34.95) \text{ IN.}$$

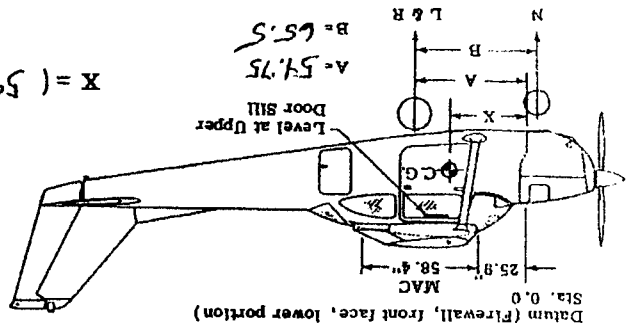

- Preparation:
 - Inflate tires to recommended operating pressures.
 - Remove all wing tank drain plugs to remove all fuel.
 - Remove oil sump drain plug to drain all oil.
 - Move all sliding seats to the most forward position.
 - All seat backs should be in the most nearly vertical position.
 - Put flaps in the fully retracted position.
 - Place all control surfaces in neutral position.
- Leveling:
 - Place scales under each wheel (500# nose, 1000# each main, minimum capacity for scales).
 - Deflate nose tire to center bubble on level (See Diagram).
- Weighing:
 - With the airplane level and brakes released, record the weight shown on each scale. Deduct the tare, if any, from each reading.
- Completing the Form:
 - Using weights from (3) and measurements from (4) the airplane weight and C. G. can be determined.
 - Obtain licensed empty weight by adding weight and moment of unusable fuel (see other side) to airplane empty weight and moment.
- Measuring:
 - Obtain measurement "A" by measuring horizontally (along the airplane center line) from a line stretched between the main wheel centers to a plumb bob dropped from the firewall.
 - Obtain measurement "B" by measuring horizontally and parallel to the airplane center line, from center of nose wheel axle, left side, to a plumb bob dropped from the line between the main wheel centers. Repeat on right side and average the measurements.

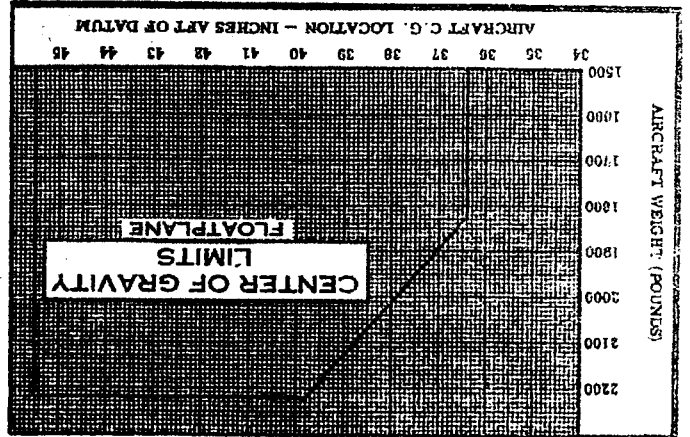
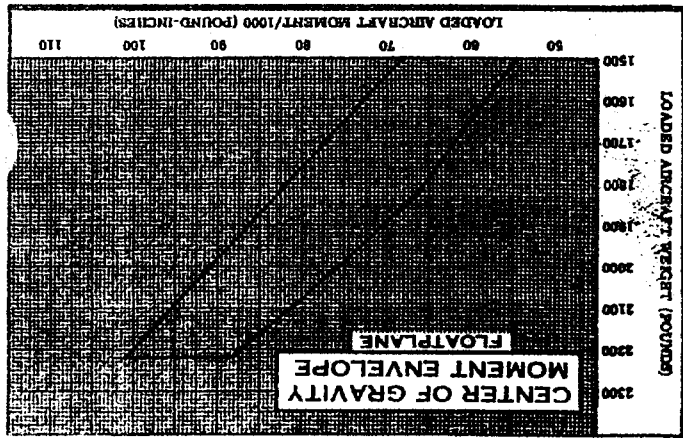

IT IS THE RESPONSIBILITY OF THE PILOT AND AIRPLANE OWNER TO INSURE THAT THE AIRPLANE IS LOADED PROPERLY. THE EMPTY WEIGHT C.G. & USEFUL LOAD ARE FOR THE AIRPLANE AS DELIVERED FROM THE FACTORY. REFER TO FORM FAA-337 WHEN ALTERATIONS HAVE BEEN MADE.

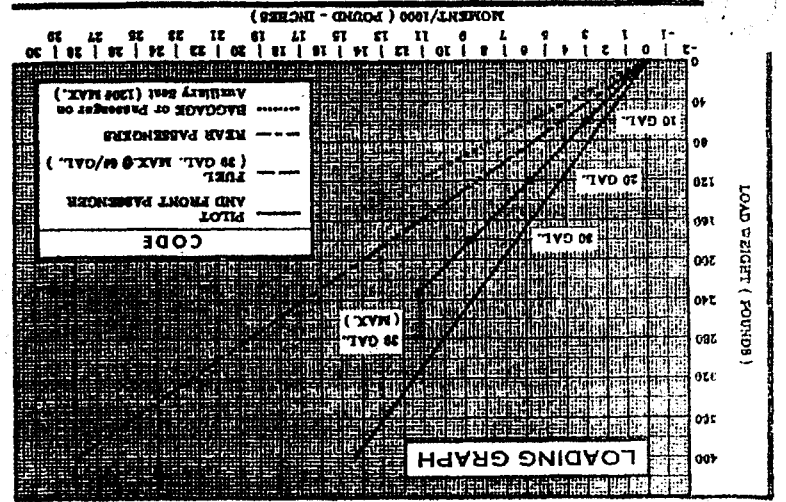
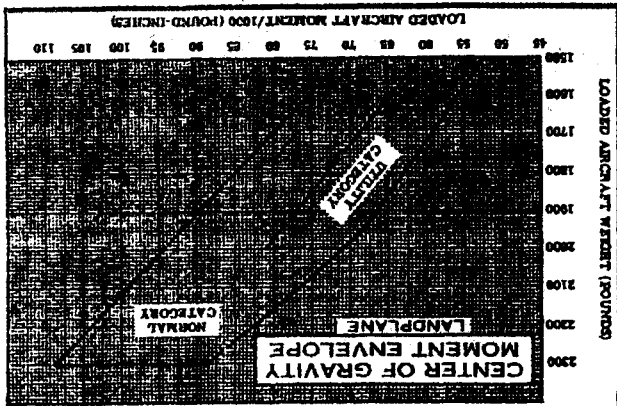
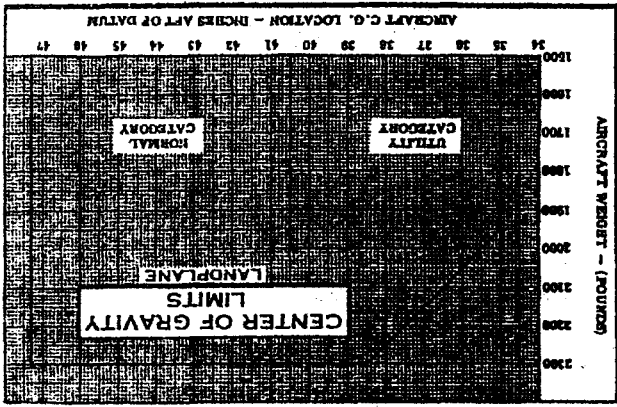

The loading meets all balance requirements. Locate this point (2300;) on the C.G. Moment Envelope. Since the point falls within the envelope

Total Loaded Airplane = 2300

Weight C.G. Arm Moment (lbs) (inches) (lb-ins/1000)	Licensed Empty Wt.	Oil (8 Qts.)	& Front Passenger	Fuel	Rear Seat Passengers	Baggage
2300	15	-20.0	340	48.0	340	95.0
			12.2		70.0	23.8

(GROSS WEIGHT.) - (LICENSED EMPTY WT.) = USEFUL LOAD (2300 LBS) - () = (LBS)

C.G. MOMENT ENVELOPE INSTRUCTIONS

- To the licensed empty weight add weight of all items to be carried.
- To licensed empty weight moment add moment of all items to be carried.
- Locate point determined by I & II and if it falls within the C.G. moment envelope the loading is satisfactory.

ITEM	Weight (lbs.)	C.G. Arm (inches)	Moment (lb. ins.)
Standard Airplane (Empty, Dry & Unpainted)	1636	34.96	57194.56
Optional Equipment			
Special Installations (DMCR Approved)			
Paint Std. Stripes Over-All Fuel load	261.3	46	12019.8
Unusable Fuel (3.0 Gal)	18.0	46.0	828
Licensed Empty Weight = Total of Items Above	1392.7	33.03	46002.76

Aircraft Serial No. _____ F. A. A. Registration No. _____ Date: _____

Weight & Balance Data

CESSNA AIRCRAFT COMPANY
WICHITA, KANSAS

MODEL 172F

1965